



## CAST IRON BARRIER



Cast Iron Barrier (DUBA)

### **1. Purpose and technical characteristics:**

Cast Iron Barrier (DUBA): DUBAs are used to pedestrians sidewalks, bicycle sidewalks, and closed parking lots from traffic and to prevent inappropriate parking. In other words, DUBAs can be considered as a barrier and protection against sudden accidents. It is possible to prevent physical and psychological damage to living beings and the environment as a result of vehicles colliding with DUBAs during sudden accidents.

### **2. Structure and working principles:**

Cast Iron Barrier: It consists of a single part and is made of EN GJL 250 material in accordance with EN 1561 standard. It is anchored to the ground by 4 bolts and acts as a barrier.



### 3. Technical details and properties:

#### 3.1 External views and dimensions of connections

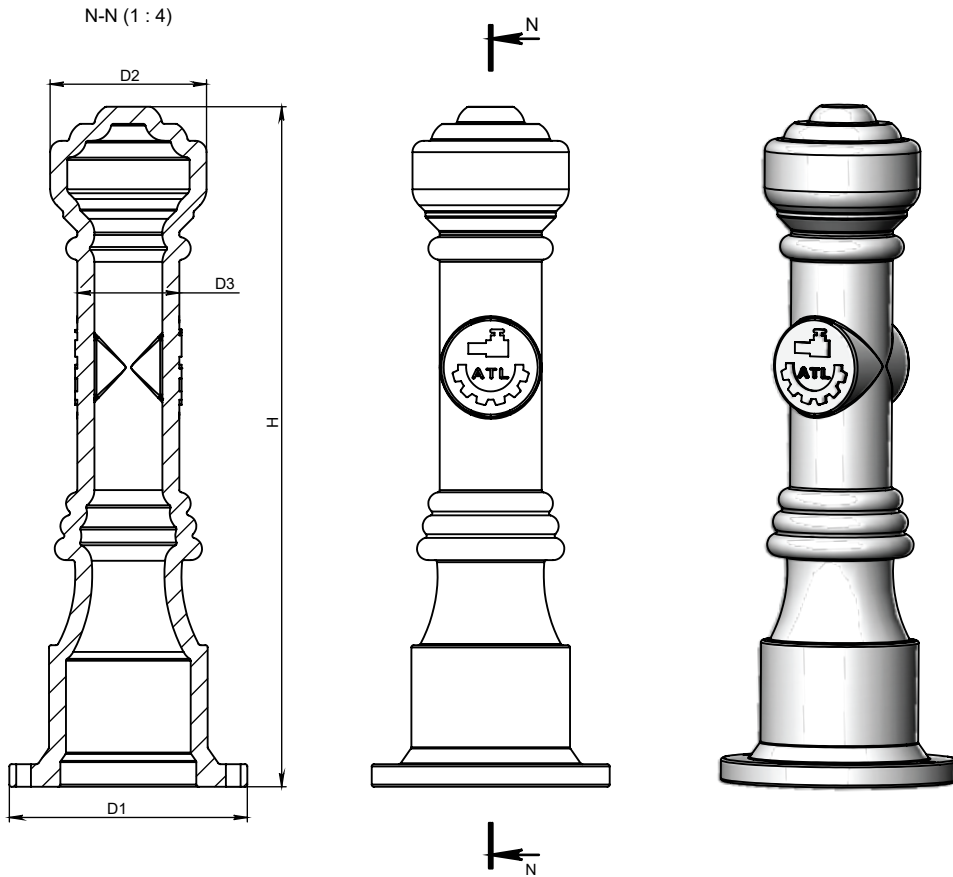

No	DETAIL	MATERIAL	QUANTITY
1	Body	EN GJL 250	1

H	D1	D2	D3
600	210	138	90



#### **4. Description of construction:**

Cast Iron Barrier: Made of GG 25 material in accordance with EN 1561 standard. It is coated with matte Bitium paint that protects against erosion and corrosion.

#### **5. Safety instructions:**

Broken or damaged DUBAs should be replaced with the new ones immediately. Otherwise, the DUBA product used in a damaged or unusable condition may lose the functions described in the first paragraph, which is dangerous for the environment.

#### **6. Maintenance requirements:**

Bodies that needs repairing must be replaced without repair (welding, etc.) to meet the safety conditions specified in paragraph 5.

#### **7. Installation instructions:**

Prior to installation, the seat surface must be leveled with concrete and anchored to the concrete with 4 bolt holes on the DUBA.

#### **8. Storage information:**

Must be stored in a warehouse.

#### **9. Transportation:**

Suitable for transportation by any type of vehicle with the right of carriage. Transportation without packaging is prohibited.

#### **10. Warranty:**

The product is certified. The AZERTEKNOLAYN LLC guarantees consumers for 1 year from the date of commissioning (excluding climate conditions, installation and user defects) in compliance with the rules of transport, storage, installation and operation. The total service life of the cast iron barrier is 10 years, excluding moving parts.

In case of violation of installation rules, claims on the quality of the irrigation hydrant are not accepted.